

HBFRF1749-3BCOM

Hamilton Beach

17 cu. ft. Chest Freezer, Double Door



Signature Features

Garage Ready

- Freezer can perform stable and consistent in temperatures from 0°F to 110°F (-17°C to 43°C)

Double Door Design

- Double door for more flexible access when you store and take out of foods. Only one door open can while using make you save more energy.

Big Capacity for Organization

- 17.1 cu. ft. capacity (484.2 Liter) holds all of your families' favourite frozen foods and treats.

2 Removable Wire Storage Baskets

- Stay organized with removable baskets that can keep your favorite frozen foods close at hand.

Available Color



Garage Ready

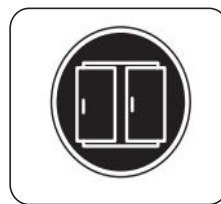

Double Door for Flexible Access



Lock&Key for Each Door



2 Removable Wire Storage Baskets

Design

- Garage ready
- Two door
- 17 cu.ft. Capacity
- Lock and key for each door
- External handle for each door
- Power-On indicator light
- Compressor -Run indicator light

Convenience

- Front mounted mechanical thermostat
- Front defrost water drain
- 2 Wire Basket
- 6 wheels for easy movement
- 2 safety lock&key
- 2 external handles

Performance

- All-Around Cooling
- High efficiency
- Large Freezing Capacity

Rating

DOE Rated: 325 kWh/yr
cCSA_{US} Certified
CFC Free

HBFRF1749-3BCOM

Hamilton Beach

17 cu. ft. Chest Freezer, Double Door

Installation Requirements

- Solid, level surface without carpeting or flooring that may obstruct ventilation
- Away from direct sunlight
- Adequate room for opening and closing the door
- Away from a heat source
- Room for maintenance and servicing
- Temperature range: between 38°F (3°C) and 110°F (43°C)

Dimensions

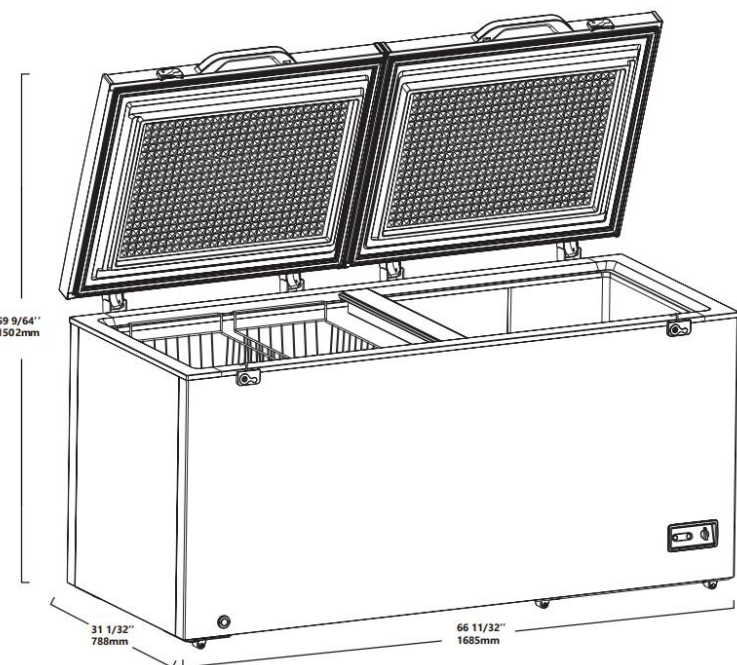
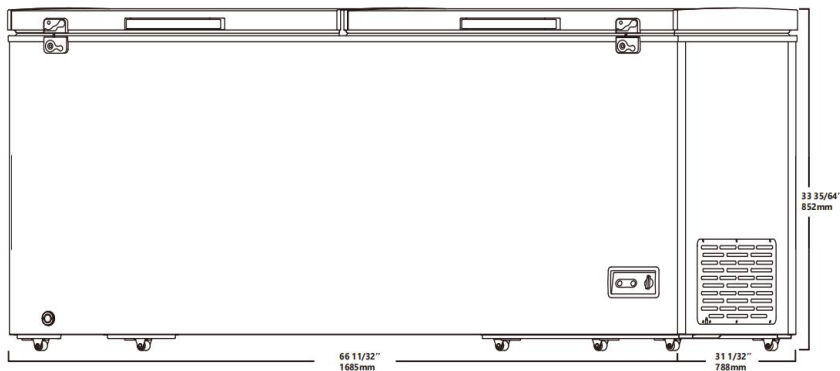

Total Capacity: 17 cu. ft.

- 2 Doors
- 2 Wire Basket
- 6 Wheels
- 2 Lock & keys
- 2 External handles
- 7 Levels temperature thermostat for choosing, design it can make you adjust temperature according to your storage.

Warranty

One (1) Year Parts and Labor

To make a warranty claim, please email support2@curtiscs.com or call 1-800-968-9853.

Product Dimensions & Weight

Dimensions (WxHxD with handle, hinge and door closed): 66 ¹¹/₃₂" x 33 ³⁵/₆₄" x 31 ¹/₃₂"

Dimensions (WxHxD including handle and hinge, with max opening angle):

66 ¹¹/₃₂" x 59 ⁹/₆₄" x 31 ¹/₃₂"

Weight: 153 lbs

Shipping Dimensions & Weight (WxHxD)

Dimensions: 68 ⁷/₆₄" x 34 ²⁹/₆₄" x 30 ⁵/₁₆"

Weight: 170 lbs

Color
White

Model #
HBFRF1749-3BCOM

UPC Code
058465827137

※ Actual color may vary. Design, specifications, and color availability are subject to change without notice. Non-metric weights and measurements are approximate.

Hamilton Beach® is a registered trademark of Hamilton Beach Brands, Inc. used under license by Curtis International Ltd.

For service assistance and product information, please call: 1-800-968-9853. Curtis International Ltd. 7045 BECKETT DRIVE, UNIT 15, MISSISSAUGA, ON, L5S 2A3 www.curtisint.com